

Technical Handbook

EASY BLADE



www.varta-ag.com/asb

Content

- 1 Caution/Warning statements..... 4
 - 1.1 General safety signs 4
 - 1.2 General hazard sources 4
 - 1.3 Safety overview of Battery Management System (BMS)..... 6
 - 1.4 Certification..... 6
- 2 Contact Details7
- 3 Introduction of Easy Blade 8
 - 3.1 Definitions and standards 8
 - 3.2 General design and application criteria 9
 - 3.3 Features10
- 4 Reference Table: Easy Blade.....11
- 5 Description: Easy Blade12
 - 5.1 Included in the box.....12
 - 5.2 Additional systems requirements.....12
 - 5.3 Push Button.....13
 - 5.4 LED indications.....13
- 6 System Setup14
 - 6.1 Mechanical connection14
 - 6.2 Electrical connection16
 - 6.3 Configuration of a system.....17
 - 6.4 Start the battery/system18
 - 6.5 Shut-down.....20
- 7 Power Modes.....20
 - 7.1 Condition 1: Shut down timer and shut down current (Deadband)20
 - 7.2 Condition 2: Keep power timer.....21
- 8 User Specific Changeable Parameters.....21
- 9 Operation.....23
 - 9.1 Pre charge circuitry.....23
 - 9.2 On / Off switch logic24
 - 9.3 Mosfet states.....25
- 10 Baud Rate.....26

10.1	Option 1: via customer objects.....	26
10.2	Option 2: via push button.....	26
11	Easy Blade - Cooling concept.....	28
12	Charging.....	28
12.1	Energy recuperation	29
12.2	Wireless charging	29
12.3	Full charge criteria.....	30
13	Error	30
14	The CAN Protocol.....	31
14.1	Communication within the battery system	31
14.2	Communication sent by the battery master (for application).....	31
14.3	Communication sent by the battery master (for charger)	34
14.4	Reserved CAN IDs.....	35
15	Life Time / Safety.....	35
15.1	Lifetime.....	35
15.2	Safety & Operation Limits.....	36
15.3	Storage	36
16	Calculation: Full charge capacity.....	37
17	Balancing	37
17.1	Module level	37
17.2	System level.....	37
18	Appendix	37
18.1	Communication cable drawing:.....	38
18.2	Charging cable	39

Legal notice

Original Instruction Manual

Nürnberg Straße 65
86720 Nördlingen
Germany

<https://www.varta-ag.com/de/>

*Tel.: 0049 9081 240 86 60
power@varta-ag.com*

Version 8

Date: February 2026

About this manual



Please read this manual and instructions carefully before attempting to use this battery in your application. It contains important information, to ensure problem free performance of your batteries. Damage to the battery howsoever caused is not covered under the warranty.

Please ensure that you have the latest version of all technical materials by downloaded from below link:

www.varta-ag.com/asb

1 Caution/Warning statements



1.1 General safety signs

Symbol	Meaning
	Prohibition symbols are circular, showing a black pictogram on a white background surrounded by a red edge with a crossbar.
	Warning signs are triangular, showing a black symbol and edge on a yellow background.
	Environmental regulations are information on statutory requirements, which have to be complied with, especially during disposal.

1.2 General hazard sources



If the following instructions for handling the device are not observed, this might lead to personal injury or damage to the battery or your device, for which VARTA Storage GmbH will accept no liability. VARTA cannot control the environment where the battery is deployed and the following are not covered by the warranty: physical damage, electrical interference, moisture ingress, deliberate or repeated short circuit or failure conditions, electrical conditions which trigger the fuse protection etc.

a. Danger of electrical voltage

	 WARNING
	Contact with electrical voltage!
	Risk of fatal injury from electric shock!
	<ul style="list-style-type: none"> ➔ Keep the module always sealed. ➔ Pay attention to any damage of electrical equipment! Eliminate defects immediately! ➔ Do not open the module. ➔ Do not connect the modules in serial only in parallel. ➔ Do not connect the module or charger in reverse polarity.

	<p>➔ You are not allowed to disconnect the module in active mode. Hot-plugging or hot-swapping is not allowed in active mode! There is a risk of short circuit between the battery modules. Only in shut-down mode old or damaged modules can be replaced with new modules. Even modules with new cell chemistries are supported if available in the future.</p>
--	--

b. Danger from water / dust

	 WARNING
	<p>Entry of water or other liquids and dust into the module!</p> <p>Possible mortal danger and material damage!</p> <ul style="list-style-type: none"> ➔ Do not use water for cleaning the module. ➔ Never place containers with fluids (beverage containers and the like) on electrical systems. ➔ Do not clean the system with agents containing acid, lye or solvents. ➔ Ensure that the battery compartment is not accessible by water, other liquids and dust. <p>The battery is rated to IP 30. The end application must ensure a higher level of protection against water and particle ingress, it is the customer's responsibility to provide a suitable outer casing or enclosure that meets these enhanced requirements in accordance with VARTA product specifications.</p>

c. Danger from wrong handling

	ATTENTION
	<p>Ensure proper handling!</p> <p>Risk of material damage, because of wrong handling.</p> <ul style="list-style-type: none"> ➔ The relative humidity must not exceed 85%. ➔ A precharge path must be implemented. (see chapter 9.1)

d. Danger from heat

	ATTENTION
	<p>Insufficient ventilation of the system!</p> <p>Overheating of the system possible!</p> <ul style="list-style-type: none"> ➔ Keep the ventilation openings clear. ➔ Ensure sufficient ventilation.

	ATTENTION
	<p>Heat input due to direct sunlight or devices emitting heat!</p> <p>Overheating and damage of the system possible!</p> <p>➔ Protect the system against direct sunlight.</p> <p>➔ Do not use fan heaters or the like near the module.</p>

1.3 Safety overview of Battery Management System (BMS)

The battery contains three levels of safety, which is controlled by the BMS.

Level 1 Protection for over-voltage/ under-voltage / over-current / short-circuit / over-temperature / under-temperature. It is controlled by the BMS software and is non-permanent.

Level 2 Protection for over-voltage/ under-voltage / over-current / short-circuit / over-temperature/ under-temperature. It is controlled by the BMS software and is permanent.

Level 3 Protection (passive) with current fuse on board.

1.4 Certification

The battery is qualified acc. to UN Recommendations on the Transportation of Dangerous Goods, UN Manual of Test and Criteria, Part III, subsection 38.3 (ST/SG/AC.10/11/Rev. 5). This battery is certified according to UN38.3, IEC62133-2:2017, IEC 62619, IEC 60335, UL 2595 and UL2271.

List of Certified Charging Devices Compliant with UL2271 and IEC62619 Standards (Only the chargers specified below are authorized for use).

Description	Material number	Remark
Easy Charger – 24 V* (1.0 kW)	57020101401	Easy Blade 24 V
Easy Charger – 36 V* (1.2 kW)	57022101401	Easy Blade 36 V
Easy Charger – 48 V* (1.5 kW)	57021101411	Easy Blade 48 V
Easy Charger – 48 V (3.3 kW)	57023101401	including wires, Easy Blade 48 V
Delta: MOOV air 01	N/A	Easy Blade 24 V Easy Blade 36 V Easy Blade 48 V
Wiferion: etaLINK3000	N/A	
Axima: ALLtrac 48E50, 48D50, 48D100, 48D150, 48D200	N/A	

2 Contact Details



To sample, buy or discuss any of the products in the Application Specific Batteries range:

USA	EUROPE	ASIA
<p>Varta Microbattery, Inc. 555 Theodore Fremd Ave Suite C-304 Rye, NY 10605, USA asb@varta-storage.com Tel: +1 (914) 592-2500 www.varta-ag.com/asb</p>	<p>Avnet Abacus Marc Eichhorn batteries@avnet-abacus.eu Tel.: +49 7152 300966 Mo.: +49 172 6331 924 www.avnet-abacus.eu</p>	<p>VARTA Microbattery Pte. Ltd. 300, Tampines Avenue 5, #05-01 Tampines Junction, 529653 Singapore Tel +65 6 260 58 01 Fax +65 6 260 58 12</p>
<p>Arrow Electronics, Inc. 9201 E. Dry Creek Rd Centennial, CO 80112, USA www.arrow.com</p>	<p>Arrow Europe Mr. Christian Jacobs christian.jacobs@arrow.com Tel: +49 6102 5030790 www.arrow.com</p>	<p>VARTA Microbattery Pte. Ltd. Room 1702-3, 17/F., Fullerton Centre 19 Hung to Road, Kwun Tong Tel +852 28 98 83 73 Fax +852 28 97 76 09</p>
<p>Sager Electronics customerservice@sager.com Tel: +1 8007243780 www.sager.com</p>	<p>Allgäu Batterie GmbH & Co. KG Mr. Ralf Benecke ralf.benecke@allgaeubatterie.de Tel: +49 8374 24124-94 Mo: +49 151 70192398</p>	<p>VARTA Microbattery Japan K.K Kyobashi Y'SUS Bldg, 3F. 1-6-12, Kyobashi, Chuo-Ku Tokyo 104-0031, Japan Tel +81 3 35 67 81 71 Fax +81 3 35 67 81 75</p>
	<p>Texim Europe Mr. Yves Van Hullebusch yves.van.hullebusch@texim-europe.com Tel.: +32 2 462 0123 Mo.: +32 479 422 338</p>	<p>VARTA Microbattery Pte. Ltd. 3F, No 85, Xinhua 1st Rd. Neihu Dist. Taipei 11, Taiwan Tel +886 233 931 557 Fax: +886 233 931 556</p>

For more information visit our website www.varta-ag.com/asb

3 Introduction of Easy Blade

Easy Blade is VARTA's-range of lithium-rechargeable battery products from VARTA Storage GmbH, offering products in the voltage range of 24V, 36V and 48V for modern systems and applications.

We offer a growing range of battery packs that are immediately available for high-energy or high-power applications. All Easy Blades are fitted with an electronic battery management system (BMS) with protection against unsafe conditions.

This product is not intended for use on public roads. It has been developed exclusively for off-road or closed-course environments. Please ensure compliance with all applicable local laws before installation or use. The customer is responsible for ensuring that the integration of this product complies with VARTA's specifications and the requirements of the final application.

SYSTEM HIGHLIGHTS OF VARTA STORAGE ASB RANGE:

▶ Excellent energy density	▶ Zero maintenance requirements
▶ Different form factors	▶ Low self-discharge and wide temperature range
▶ ~24V, ~36V and ~48V versions	▶ Up to 40kWh systems using modular approach
▶ IEC62133-2:2017 certification	▶ Mechanical stacking/locking design
▶ CAN Bus Communications (CANopen)	▶ ISO9001 certified for design and manufacture
▶ Excellent cycle life (see PI-Sheet)	▶ 2-year manufacturer's limited warranty

3.1 Definitions and standards

VOLTAGE DEFINITIONS

<p>Open Circuit Voltage (OCV):</p> <p>is the difference of electrical potential between two terminals of a device when disconnected from any circuit, dependent on battery model, temperature, storage duration and state of charge.</p>	<p>End of Discharge Voltage (EoD):</p> <p>The voltage at the end of discharging depending on discharge rate and temperature.</p> <p>End of Charge Voltage (EoC) should also be referenced from the individual specifications.</p>
---	---

CAPACITY DEFINITIONS

The capacity C of a cell is defined by the discharge current I and the discharge

$$\text{time } t: C = I \cdot t$$

I = constant discharge current

t = duration from the beginning of discharge until the end of discharge voltage is reached

Nominal Capacity: The nominal capacity C denotes the capacity amount in Ah (Ampère hours) that the battery can deliver at the 5h discharge rate (0.2 C). The reference temperature is $+22^{\circ}\text{C} \pm 3^{\circ}\text{C}$, if not otherwise stated and the final discharge voltage will also be stated.

Available Capacity:

Factors which affect the available capacity are:

- ▶ Rate of discharge
- ▶ End of discharge voltage
- ▶ Ambient temperature
- ▶ State of charge
- ▶ Battery age
- ▶ Cycle history of the battery

At higher than usual discharge rates the available capacity is accordingly reduced.

CURRENT DEFINITIONS

Charge and discharge rates may be given as multiples of the rated capacity (C) in amperes (A) with the term C.

Example:

Rated Capacity $C = 1000 \text{ mAh}$

$0.1 C = 100 \text{ mA}$, $1 C (A) = 1000 \text{ mA}$

Nominal Discharge Current:

The nominal discharge current of an ASB battery is the 5-hour discharge current (0.2 C). It is the current at which the nominal capacity of a cell is discharged in 5 hours.

$$I = C/t = C/5 = 0.2 C \text{ when } t = 5 \text{ h}$$

3.2 General design and application criteria

Choose the best suitable battery from our range according to your needs relating to the specific application and its corresponding planned operation conditions.

The most important criteria for the type-selection are these:

- ▶ Required minimum operating time
- ▶ Charging rates required vs. calendar life target
- ▶ Max. and average current drain
- ▶ Min. and max. voltage of operation
- ▶ Operating temperature range
- ▶ Mechanical properties
- ▶ Available space
- ▶ Environmental conditions

Easy Blades are equipped with our specially selected and carefully designed safety electronic modules (BMS) which prevent the risks of hazards due to any foreseeable abuse / misuse. Nevertheless, it is required that any application is designed so that the battery may operate within its normal specification without the safety features being triggered by end-user behaviour.

3.3 Features

Easy Blades are first choice for a number of modern high-tech products in fields such as robotics, automated guided vehicles (AGV), related logistics and agricultural solutions and more. They provide long lasting, reliable main power, occupying a minimum of space and weight in the corresponding devices.

VARTA Storage batteries fulfil the most important design-in requirements: Reliable high-power output, design flexibility with minimized space requirements and a long life.

Feature	Advantage	Customer Benefit
UN38.3 certified	Approved for transport	Supplier's test summary available
IEC62133-2:2017 certified	Ready for design-in for certified applications	Reduced design-in cost
Multiple form-factors with modular design	Design flexibility	Product design convenience
Excellent overall performance	High energy and high cycle life	Lower total cost of ownership and highly satisfying over the long-term
Complete battery module solution, zero maintenance	Fit and forget design	Low cost of maintenance in the field
CAN Communications	Smart battery management, regardless of module size	Battery behaviour, charging, safety can all be controlled and monitored

4 Reference Table: Easy Blade



*Illustration only

Product	Easy Blade 24 V	Easy Blade 36 V	Easy Blade 48 V	Easy Blade Baby 24 V
Order Number (VKB)	56654 799 096	56654 799 089	56654 799 092	56672 742 098
State of charge	< 30 %	< 30 %	< 30 %	< 30 %
Design capacity (Ah)	64	44,8	32	17,4
Nominal voltage (V)	25,9	37	51,8	25,2
Min. discharge voltage (V)	21 V	30 V	42 V	21 V
Max. charge voltage (V)	29,05 V	41,5 V	58,1 V	29,05 V
Operating temperature				
Charging	0°C to + 50°C	0°C to +50°C	0°C to + 50°C	0°C to + 45°C
Discharging	-20°C to +55°C	-20°C to +55°C	-20°C to +55°C	-20°C to +50°C
Storage	1 to 3 months at -20°C to +45°C 1 year at -20°C to +24 °C	1 to 3 months at -20°C to +45°C 1 year at -20°C to +24 °C	1 to 3 months at -20°C to +45°C 1 year at -20°C to +24 °C	1 to 3 months at -20°C to +45°C 1 year at -20°C to +25 °C
Life expectancy (typical) at	0,5 C/ 0,5 C, 22°C ± 2°C	0,5 C/ 0,5 C, 22°C ± 2°C	0,5 C/ 0,5 C, 22°C ± 2°C	0,5 C/ 0,5 C, 22°C ± 2°C
No. of cycles (on Cmin)	1,200 (80%)	1,200 (80%)	1,200 (80%)	1,200 (80%)
Miscellaneous				
NTC	Yes	Yes	Yes	Yes
IP	30	30	30	30
Active cooling (Fans)	Yes	Yes	Yes	No
Certification	UN38.3 IEC62133-2:2017 UL2595 IEC60335 IEC62619:2022 UL2271	UN38.3 IEC62133-2:2017 UL2595 IEC60335 UL2271	UN38.3 IEC62133-2:2017 UL2595 IEC60335 IEC62619:2022 UL2271	UN38.3 IEC62133-2:2017 UL2595 IEC60335

5 Description: Easy Blade



5.1 Included in the box

Two module connectors (including the two screws) will be delivered together with the battery. (See 6.1)

5.2 Additional systems requirements

a. Power cable

Power cables are not provided as requirements differ in all use cases. These are available from our distributors. See contact details on page 7. It is recommended to use an M6 screw type for the negative terminal and an M8 screw type for the positive terminal. For connection of the modules an additional bus bar or wires with cable lug are needed.

b. Communication cable

The communication cable is not provided. These are available from our distributors. See contact details on page 7. It is recommended to use Tyco Amphenol LTW 12-05BMIA-SL8001 or similar. See page 38 for the wire drawing.



c. CAN termination resistor

The CAN termination resistor is not provided. These are available from our distributors. See contact details on page 7. It is recommended to use Phoenix Contact 1507816 or similar.



A system without CAN communication to the Host needs two CAN termination resistors of 120 Ohm each. One CAN termination resistor has to be connected to the M12 connector

of the first module and one CAN termination resistor has to be connected to the M12 connector of the last module. In this way the resistors are placed at the physical ends of the CAN bus.

Systems with CAN communication to the host only need to have one CAN termination resistor of 120 Ohm on the last module which is connected. In this case the host needs its own termination resistor.

The Delta Q Charger RC1000 and RC1200 has no built-in termination resistor. The Varta version of the ICL1500 charger has a built-in termination resistor. To enable it, pin 2 has to be shorted to pin 11.

Please note: Our Varta charger cable (see drawing on page 39) has an built-in termination resistor between CAN_H and CAN_L. Please make sure that pin 2 is not shorted to pin 11 if our charging cable is used in combination with the ICL1500 charger to avoid incorrect termination of the CAN Bus.

Please make sure that the system is terminated at both physical ends of the CAN Bus!

d. Charger

We recommend VARTA approved chargers which are already programmed with compatible firmware and tested. The charger datasheets can be provided on request. (For more information on charging see chapter 12).

Description	Material number	Remark
Easy Charger – 24 V* (1.0 kW)	57020101401	Easy Blade 24 V
Easy Charger – 36 V* (1.2 kW)	57022101401	Easy Blade 36 V
Easy Charger – 48 V* (1.5 kW)	57021101411	Easy Blade 48 V
Easy Charger – 48 V (3.3 kW)	57023101401	including wires, Easy Blade 48 V

*The charging cable is not provided. These are available from our distributors. See contact details on page 7. It is recommended to use TE Ampseal or similar. See page 39 for the wire drawing.

5.3 Push Button

Push the button to wake up and to shut-down the module. For more than one battery in parallel the button only needs to be pushed on one module. (See 6.4)

5.4 LED indications

The LED is able to show three different colours steady or blinking.

a. Switch from Deep Sleep to Active Mode



b. Switch from Active Mode to Deep Sleep

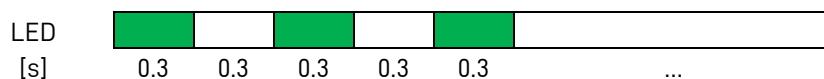

Note: As long as voltage is applied on the power terminals, the battery will continue the sequence

c. Active Mode and DSG FET or CHG FET is closed



d. Active Mode and DSG FET and CHG FET opened

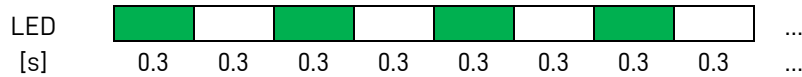

e. Deep Sleep

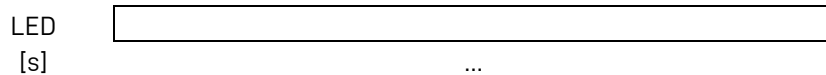

f. Irreversible error (e.g. defect fuse, defect FET, ...)



g. Reversible error (e.g. over-temperature, over-current, ...)



h. No valid Node ID or double Node ID detected

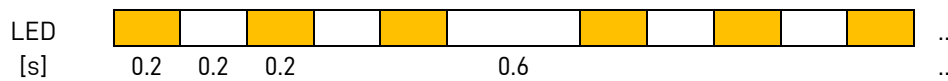

i. Switch to Bootloader Mode

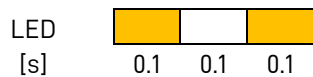

j. Bootloader is active



k. Node ID assignment in process

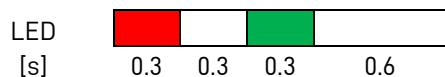

6 System Setup

6.1 Mechanical connection

Important! When installing the module in your application, it is important to ensure that load-bearing is evenly spread. Pressure or weight in a single area, especially on the metal plate is not allowed and may cause damage to the battery and internal components. For example, it is not allowed to fix the modules with a strap or similar where all of the weight could be carried in one small area. The pressure must be spread over the whole module.

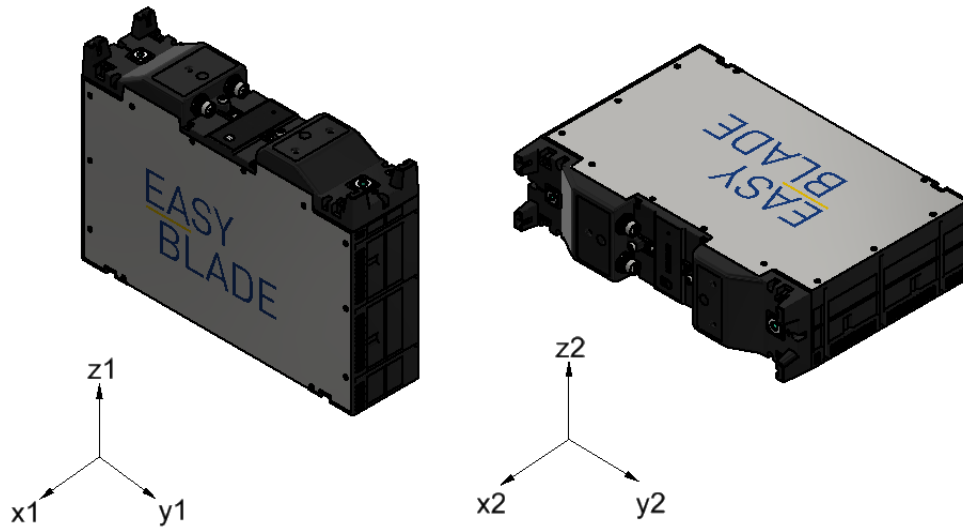

The modules can be connected in "x1" or "z2" direction via two module connectors, shown below in black. Place the module connectors inside the recess of two modules (see below picture). The module connectors are asymmetric and have a broad and a narrow side. If the orientation of the modules is wrong (e.g. in case of serial connection of the modules), the connectors will not fit properly. When the module connector is placed, insert a screw (Screw Wuerth Wueplast W1423 3x8, TX8 or Screw EJOT Delta PT WN5454 30x8, TX10) and tighten it with a torque of max 0.15 Nm). The module connector will expand and jam in the recess.

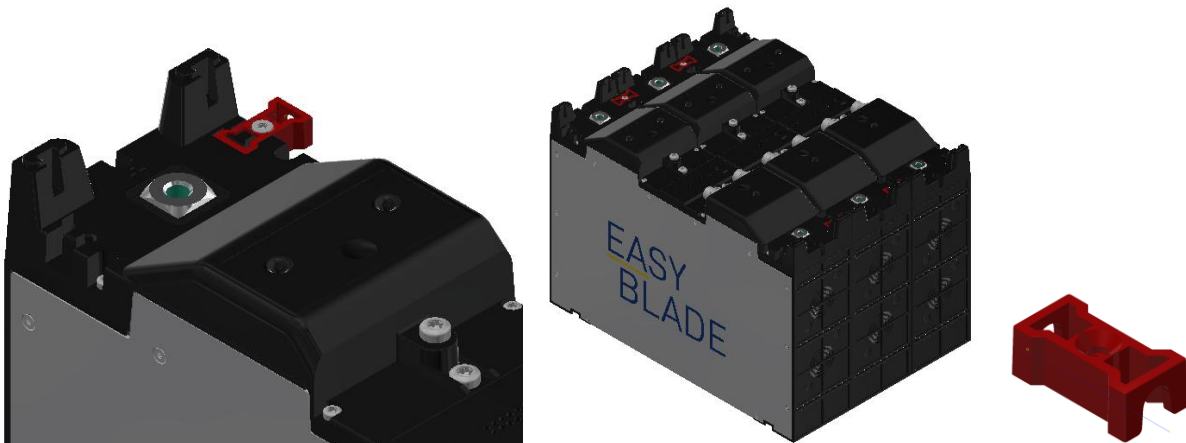

Important: The module connector will ensure correct position of the modules and add stability. The end user is responsible for creating sufficient stability of the battery system within the device with respect to the requirements of the application and variation of battery systems which can be assembled. In some cases, it is necessary to consider that additional support of the module structure should be considered in the final design of the application.

For removal of the module connector loosen the screw and remove the module connector. If the connector is stuck, use a screwdriver for pulling it out of the recess via the side opening in the connector.

The modules can be connected in z1 directions. You can stack the batteries via the design features on the bottom and on the top of each module. (See picture below). Please note the stacking features are only for orientation and guidance – not for fixation. The user is responsible, to make sure that the module cannot move during operation.

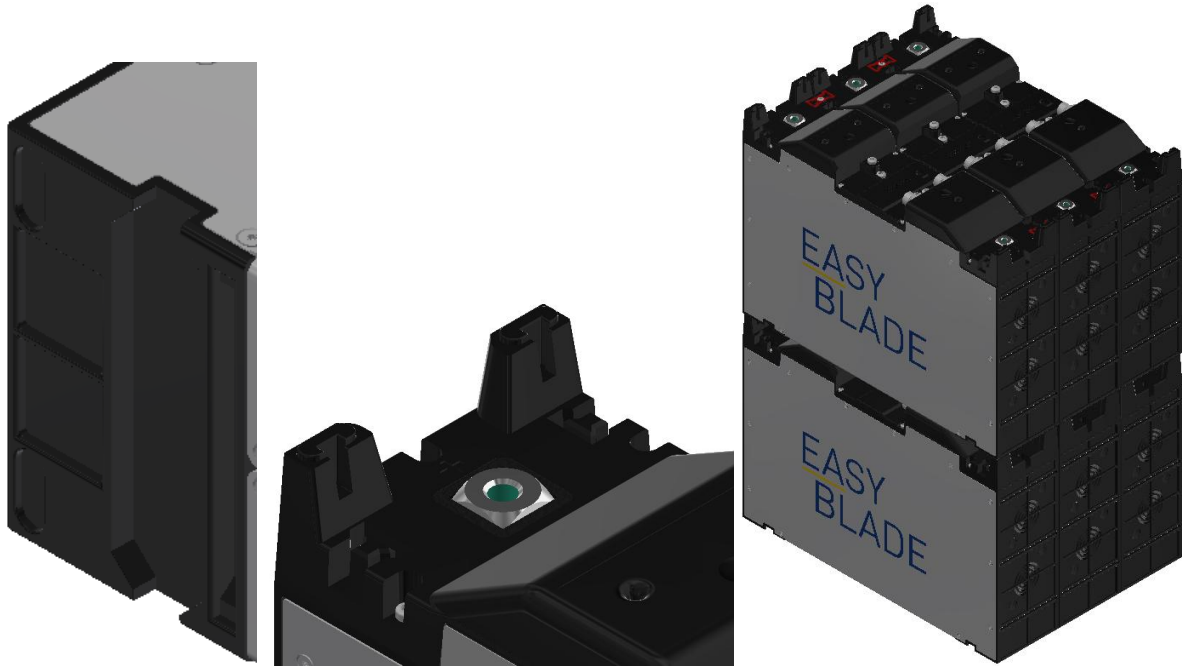

Below table shows the permitted layers in a specific direction:

Direction	Maximal Layers	Comments
Z1	3 layers	To avoid too much weight
Y1	1 layer	To ensure proper ventilation
Z2	5 layers	To avoid too much weight
Y2	1 layer	To ensure proper ventilation

6.2 Electrical connection

It is not allowed to connect the modules in series! Only connect the battery modules in parallel. Do not mix up 24V, 36 V and 48V battery modules within a single system.

Please note: It is recommended to use all modules within a system with the same FW Version and HW Version (VKB Number). If different FW versions or HW Versions within a system are used it might lead to unexpected behavior. Please check the FW version via CAN-bus and confirm the HW version using the VKB number (see table in Section 14).

Approval from VARTA is requested for the use of 24 batteries connected in parallel, based on the product design.

There are a variety of power cables and connections possible: A few suggestions from Molex and nVent:

<https://www.molex.com/en-us/products/connectors/high-power-solutions/busbars>

<https://www.nvent.com/en-us/eriflex/products/nvent-eriflex-flexibar-advanced-tinned-copper-0>

The next steps describe how to connect the battery modules in parallel.

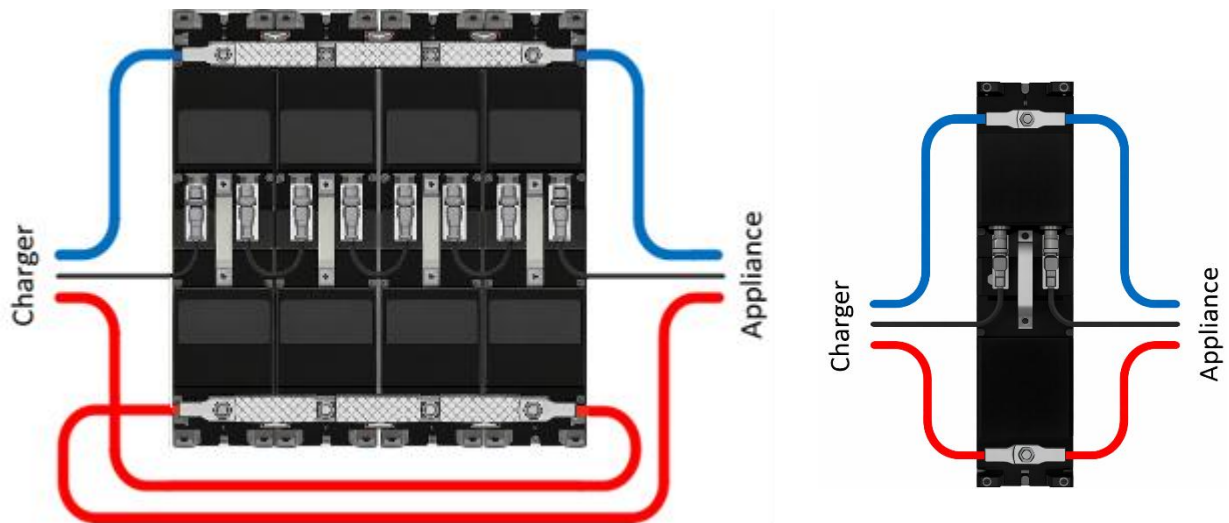

Step 1: Minus terminal

Connect the Power Minus of all modules in parallel. Tighten it with a torque of max 3.9 Nm. Please note that Power Minus is marked with the symbol -. For connection of the modules an additional busbar or wire with cable lug is needed. Please use a M6 x 16 mm screw.

Step 2: Plus terminal

Connect the Power Plus of all modules in parallel. Tighten it with a torque of max 9 Nm. Please note that Power Plus is marked with the symbol +. For connection of the modules an additional busbar or wire with cable lug is needed. Please use a M8 x 16 mm screw.

Step 3: CAN cables

Connect the CAN cables. Tighten it with a torque of max 0.6 Nm. Connect always modules next to each other (see below picture).

Step 4: CAN termination resistor

Connect the CAN termination resistor or add a CAN termination into the connector. Please make sure that the system is terminated at both physical ends of the CAN Bus.

6.3 Configuration of a system

It is necessary under the following conditions:

1. If the modules are connected the very first time.
2. If one or more modules are replaced with new module(s) in an already configured system.
3. If new modules are added to an already configured system.

Connect the batteries as described in chapter 6.1 and 6.2.

Step 1: Turn on the system by pressing the button on any battery for 3 to 5 seconds until the LEDs starts flashing orange. Alternatively, the ON/OFF signal (PIN 2) at the M12 connector can be connected to GND (PIN 3) by an external switch. LED will turn to orange (blinking).

Step 2: Press the button on any battery for at least 5s (but not longer than 10 sec.) until the LED on this battery turns red (300 ms), off (300 ms), green (300 ms) and off (600 ms) until the configuration is done (LED green). See also chapter 5.4 k.

Technical details:

Each battery gets its own fixed Node ID while configuring the system. The range from 1 to 27 is reserved for fixed Node IDs, even if the system consists only of 3 batteries. Each battery sends this PDO consisting of its own value. The master sends additional PDOs with Node 27 consisting of the summary of the whole battery system.

Batteries which are not configured will not have a valid Node ID and will also not send any messages on the CAN bus. When configuring the system by pushing the button for at least 5 seconds (but not longer than 10 seconds), the batteries will determine the master of the system dependent on the highest serial number of the batteries. The Node IDs will be assigned in order of the serial numbers. When all Node IDs are assigned, the battery with Node ID 2 switches to Node ID 1 and becomes the master of the system. Because of this, there will never be an active Node ID 2 available in the system.

Example of system with four batteries in parallel:

Network Overview

	Device Name	NMT State
0	Network	-
1	b	Operational
2	b	Pre-Op
3	b	Operational
4	b	Operational
5	b	Operational

Please switch the batteries off before adding new modules. After adding modules, start the system again. In case of orange blinking LEDs, press the push button of any battery for at least 5 seconds to reconfigure the Node IDs.

6.4 Start the battery/system

Step 1: Wake-up:

- ▶ Method 1: Push the Button (3 to 5 seconds) on one battery module (it does not matter which module) until the LED is solid green. The batteries will not turn on if the button is pushed longer than 5 seconds. This prevents turning on the battery accidentally if something blocks the button continuously.
- ▶ Method 2: Pull the ON / OFF Pin (Pin 2) of the CAN connector permanently to ground (Pin 3).

Note: Wake-Up by the external switch is prioritized. In case the battery has been turned off while the external switch was active and will be turned on again via the push button, the button only needs to be pressed for 500ms. The battery will enable discharge after one (1) second from either the push-button or On/Off pin. (In some earlier versions, the discharge is enabled after 250 milli-seconds.) See also 9.2 for switch debounce operation.

Please wait at least 3 seconds before turning on the battery again after turning off to ensure internal capacitors are fully discharged.

Caution: Floating voltage may occur on the battery terminals until a stable load (> 1 mA) is present.

Pin-out of the M12-5 connector (female connector on the battery)

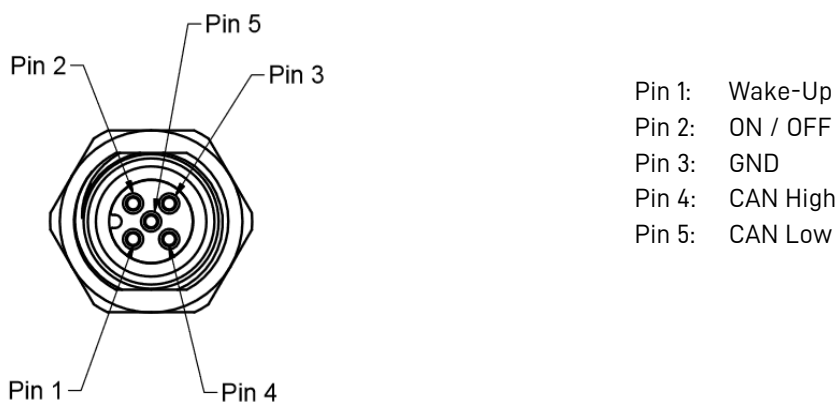

Note: All connectors (and all pins) are connected in parallel. The Wake-Up signal (Pin 1) is used in a system to wake up all batteries by pushing the button of any battery in the system. The ON/OFF signal (Pin 2) is used to wake up all batteries in a system by an external switch. After Wake-Up the battery is ready for discharge. Charging is only possible if an approved VARTA CAN charger is connected, or a suitable CAN-charger has been developed under the VARTA protocol. For communication with the application, you have to use Pin 3, Pin 4, and Pin 5.

Step 2: Check Battery Status

- ▶ Method 1: Check if the green LED on all modules is solid green.
- ▶ Method 2: Read the Battery Status Register via CAN.

If all modules are activated, continue with Step 3.

Step 3: Discharging or Charging

- ▶ Discharging: Discharging is going to start once a load is connected to the system. Discharging is possible without CAN communication to the device.
- ▶ Charging: Connect a VARTA approved CAN charger to the system. Charging starts once there is a CAN communication between Master and charger.

6.5 Shut-down

- ▶ Method 1: Push the Button on a module twice quickly within one second (it does not matter which module).
- ▶ Method 2: Switch off the battery with the external switch, which is connected to the ON / OFF pin in the CAN connector.
- ▶ Method 3: If you want to switch off the Battery, you have to send the command 0x03F3 to object 0x2010 sub. 9. If you want so switch off the system (with more than one battery), you have to send same command to 0x2010 sub. A.

7 Power Modes

There are two conditions under which the battery enters automatically shut down mode.

7.1 Condition 1: Shut down timer and shut down current (Deadband)

If no charging / discharging below a set threshold (5A default) is detected within 3h, the single module shuts-down automatically. This 3h value and the current threshold is a default and can be changed in the CAN device settings.

The default value is 3h and the value of the shutdown timer can be set via object 0x3F00.4. The default value for the current is 5 A and can be set via object 0x3F00.5. For multi-module systems, to ensure individual modules remain in-sync, it is advised that the current thresholds for the timer function are not marginal or close to the limit of under/over current to trigger the shutdown. In such cases it could potentially bring the modules out of sync, if one module timer is triggered and another not.

Steps to follow for shutdown timer:

1. Code for write permission:

Write value 0x0717 to object 0x2010.1

2. Timer value (in seconds):

Write value to object 0x3F00.4 (e.g. 604,800dec for 7 days)

3. Save changed parameter permanently:

Write 0x1c2b to object 0x2010.1

If you don't want automatic shutdown set the timer to the maximal value, which is 0xffffffff.

Steps to follow for shutdown current (Deadband):

1. Code for write permission:

Write value 0x0717 to object 0x2010.1

2. Current value (in mA):

Write value to object 0x3F00.5 (e.g. -10000 dec for - 10000 mA)

3. Save changed parameter permanently:

Write 0x1c2b to object 0x2010.1

7.2 Condition 2: Keep power timer

Once battery is fully charged (100 % SOC), battery enters shut down mode after 5 minutes by default. This timer can be changed.

Steps to follow:

1. Code for write permission

Write value 0x0717 to object 0x2010.1

2. Keep power timer (in seconds)

Write value to object 0x3F00.9 (e.g. 360 dec for 6 minutes)

3. Save changed parameter permanently

Write 0x1c2b to object 0x2010.1

If you don't want automatic shutdown set the timer to the maximal value, which is 0xffffffff.

8 User Specific Changeable Parameters

There is a specific area for "User Specific Changeable Parameters". These parameters can be accessed via CANopen Protocol and SDO transfer. For changing proceed the following steps:

Example:

1. Get Write permission:

Write "0x0717" in object 0x2010.1

2. Change Current Value to e.g. 20A (=20,000 mA) in "Normal Temp Range":

Write "0x4e20" in object 0x3F00.6

3. Save values permanent in EEPROM:

Write "0x1c2b" in object 0x2010.1

4. Reboot battery:

New value is valid only after reboot (switch off and on the battery). Below objects can be configured by the customer.

Object ID	Object Description	Write permission	Save value in EEPROM	Description	Format
0x3f00.1	Configuration string customer	0x0717 in Object 0x2010.1	0x1c2b in Object 0x2010.1	String for general purpose	32byte String
0x3f00.2	Serial number customer	0x0717 in Object 0x2010.1	0x1c2b in Object 0x2010.1	Customer can add own serial number if needed	Unsigned32
0x3f00.3	Date code customer	0x0717 in Object 0x2010.1	0x1c2b in Object 0x2010.1	Customer can add own date code if needed	Unsigned16
0x3f00.4	Shut down timer	0x0717 in Object 0x2010.1	0x1c2b in Object 0x2010.1	Shutdown timer. If standby current of application is less than the value which is defined in 0x3f00.5, the battery will switch off after expiration of the shutdown timer (default 10800s)	Unsigned32
0x3f00.5	Battery discharge current system shutdown delay threshold	0x0717 in Object 0x2010.1	0x1c2b in Object 0x2010.1	Deadband for the system. (Default - 5000 mA).	Unsigned32
0x3f00.6	Battery charge max current normal temperature (10 °C – 40 °C)	0x0717 in Object 0x2010.1	0x1c2b in Object 0x2010.1	Max current which is allowed in normal temperature range. Please note: It cannot exceed the protection threshold of the battery.	Unsigned32
0x3f00.7	Battery charge max current high temperature (40 °C – 50 °C)	0x0717 in Object 0x2010.1	0x1c2b in Object 0x2010.1	Max current which is allowed in high temperature range. Please note: It cannot exceed the protection threshold of the battery.	Unsigned32
0x3f00.8	CAN baud rate	0x0717 in Object 0x2010.1	0x1c2b in Object 0x2010.1	Baud rate can be change via this object. Default is 250 kbit/s. Possible baud rates are 125/250/500/1000	Unsigned16
0x3f00.9	Keep power timer	0x0717 in Object 0x2010.1	0x1c2b in Object 0x2010.1	Once battery is fully charged (100 % SOC), battery enters shut down mode after 5 minutes by default. This timer can be changed via this object.	Unsigned32
0x3f00.A	Battery charge max current low temperature (0 °C – 10 °C)	0x0717 in Object 0x2010.1	0x1c2b in Object 0x2010.1	Max current which is allowed in low temperature range. Please note: It cannot exceed the protection threshold of the battery.	Unsigned32

9 Operation

9.1 Pre charge circuitry

For applications with a high input capacitance, adding a pre-charge circuitry into the device is necessary to limit the inrush currents as there is no build in pre-charge circuitry in the battery. High inrush currents might trigger the short circuit protection in the battery which lead to a shutdown of the system during start-up.

Please note: Pre-charge Path needs to be implemented to protect the battery. In some cases without pre-charge Path, the discharge MOSFETs in the battery might be damaged.

The short circuit protection in the battery will be enabled if a current of 300A for 300µs is exceeded.

The application must include pre-charge circuitry. Below is an example of a typical implementation.

The input capacitor is pre-charged via a series resistor (R1). After a defined delay, which is pre-set in the timer relay, the main power path is enabled.

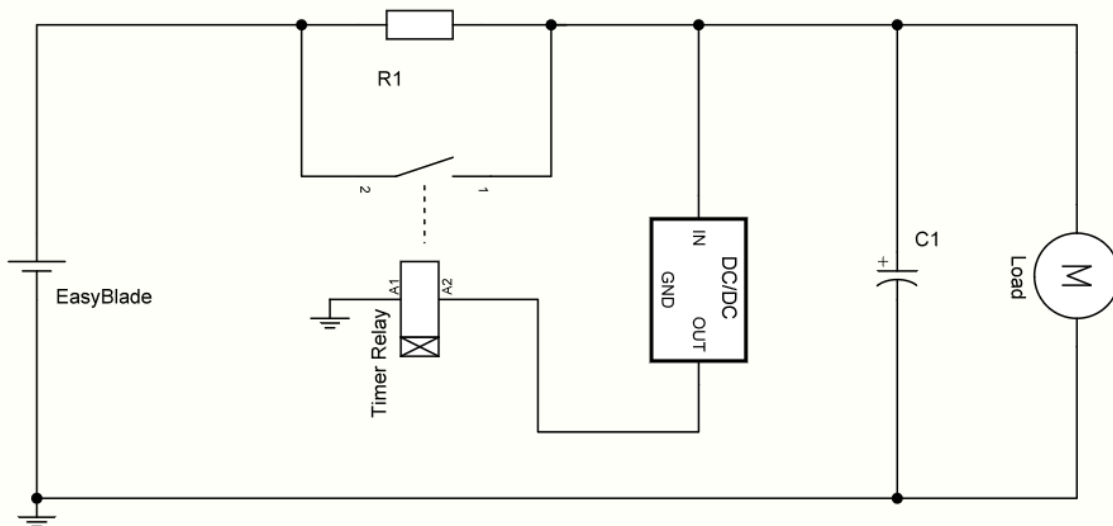

Please keep the pre-charge current as low as possible to reduce the cost for the pre-charge resistor. Typical pre-charge currents are in the range of 5A-15A.

Formula to calculate the pre-charging of a capacitor:

$$U_c(t) = U_0 \times (1 - e^{-t/(R \times C)})$$

$U_c(t)$: Capacitor voltage after time t

U_0 : Battery voltage

t : time

R : resistance of pre-charge resistor

C : Input capacitance

Example for pre-charge resistor:

TE Connectivity HSC10010RJ 100hm (+/- 5%) 100W

Example for timer relay:

Phoenix Contact 2905814

Example for relay in main power path:

Siemens 3RT2026-1AP00

9.2 On / Off switch logic

After a valid "On" condition is detected (see below), the battery will allow discharge at the end of the debounce period = one (1) second after the push-button or switch activates the "On" condition.

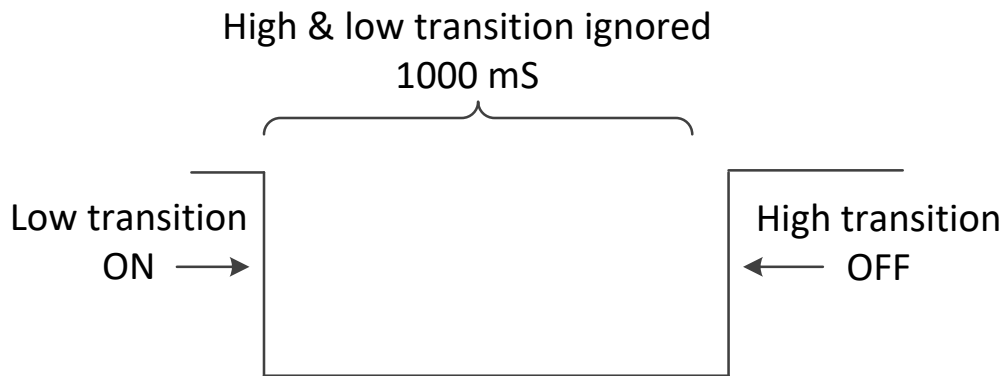

Debounce period is 1000 milli-seconds (one second) from edge detection.

Pin 2 "On/Off" Debounce Operation

- Debounce period is 1000 milli-seconds (one second) from edge detection
- If level has changed during debounce period, but a new edge is not detected, then new edge does **not** alter the state

Signal level is High, but Battery state remains "ON" (from previous Low edge):

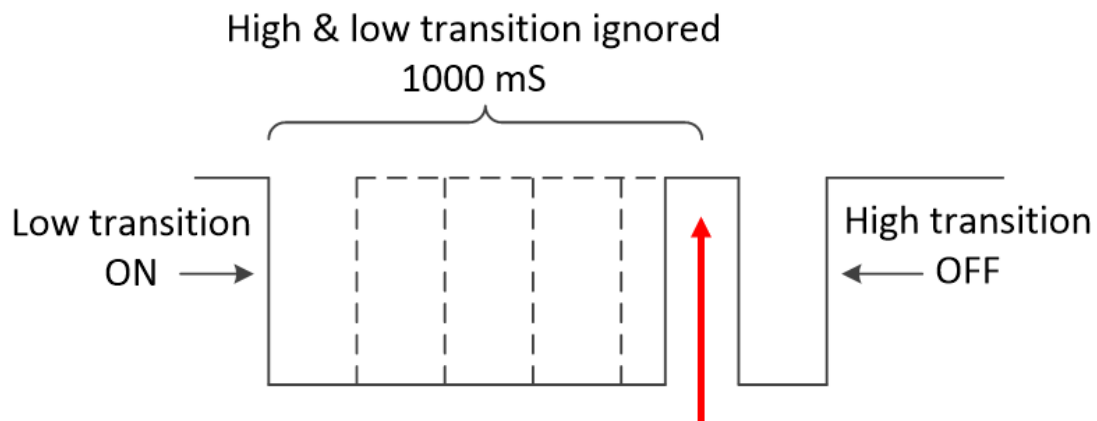

9.3 Mosfet states

Idle state: State of the battery directly after start-up (without load)

Discharge: Battery in discharge state (load greater than - 250mA)

Charge: Battery in charge state (charging current greater than 250mA)

a. Balanced

2 batteries in a balanced state (the voltage difference between the cell voltages of the two batteries must be less than the value in 0x2204.1)

Battery State	Battery 1 CHG-Fet	Battery 1 DSG-Fet	Battery 1 Bypass-Fet	Battery 2 CHG-Fet	Battery 2 DSG-Fet	Battery 2 Bypass-Fet
Idle	OFF	ON	OFF	OFF	ON	OFF
Discharge	ON	ON	OFF	ON	ON	OFF
Charge	ON	ON	ON	ON	ON	ON

b. Unbalanced

2 batteries in a de-balanced state (the voltage difference between the cell voltages of the two batteries must be greater than the value in 0x2204.1). In this example, battery 1 has a higher voltage than battery 2.

Battery State	Battery 1 CHG-Fet	Battery 1 DSG-Fet	Battery 1 Bypass-Fet	Battery 2 CHG-Fet	Battery 2 DSG-Fet	Battery 2 Bypass-Fet
Idle	OFF	ON	OFF	OFF	ON	ON
Discharge	ON	ON	OFF	OFF	ON	OFF
Charge	ON	OFF	OFF	ON	ON	ON

10 Baud Rate

There are two possible ways to change the baud rate:

10.1 Option 1: via customer objects

Steps to follow:

1. Code for write permission

Write value 0x0717 to object 0x2010.1

2. Baud rate (in kbit/s)

Write value to object 0x3F00.8 (e.g. 125 dec for 125 kbit/s)

3. Save changed parameter permanently

Write 0x1c2b to object 0x2010.1

10.2 Option 2: via push button

Switch into configuration mode "CANopen baudrate setting" while the BMS is in Active Mode it is possible to start this configuration mode by pressing the onBoard button a long time

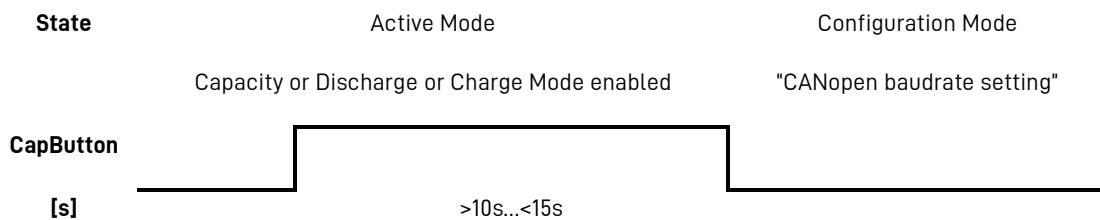

When **10s** are reached, the LED display shows short feedback to signal that the button has to be released to start the configuration. If the button is released within the mentioned time range the configuration mode starts. The BMS LED display shows the state switch. The flag `WARNING_REG_SET_CAN_BAUDRATE_PROCESS_ENABLE` is set. The BMS waits for further key pressing to change the baudrate setting or to finish this configuration mode. All other kinds of key pressing events (e.g. switch into DeepSleep Mode) and also events which occur on the External Signal GPIO were ignored during this configuration mode

Change baudrate during "CANopen baudrate setting"

While the BMS is in the mentioned configuration mode it is possible to toggle between several baud rate settings by short pressing the onBoard button. There are 4 different fix baudrate settings possible which are changed with every key press in a Sequential rotating order e.g. if the setting was 125kBd while the configuration mode was entered, after the first press 250kBd will be selected and so on.

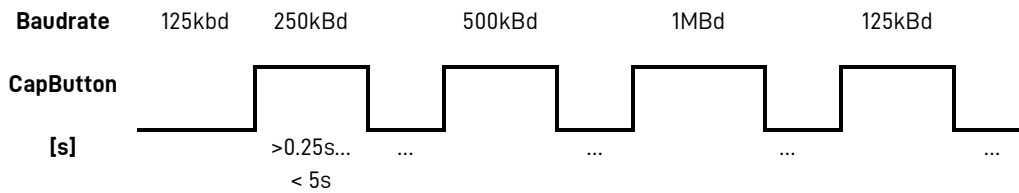

The actual selected baud rate is shown via the BMS LED display. This is only a preselection for an internal temporary table index during this configuration mode the CAN interface is not be influenced. CAN interface will only be reinitialized after the configuration is finished and the BMS will be restarted

Finish setting during "CANopen baudrate setting"

While the BMS is in the mentioned configuration mode it is possible to finish the configuration mode by pressing the onBoard button again for a long time.

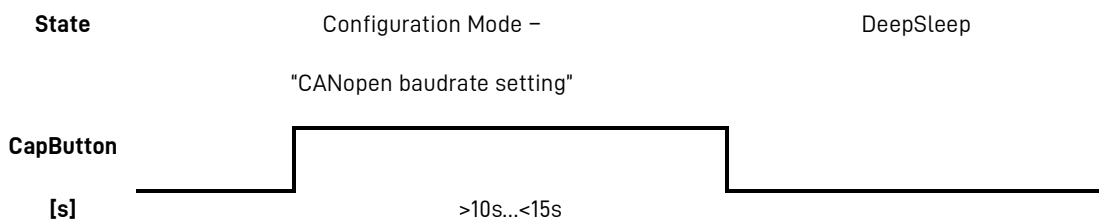

When **10s** are reached, the LED display shows short feedback to signal that the button has to be released to store the configuration. The corresponding CAN baudrate of the last selected table index is stored into the EEPROM to can be used after the next restart from DeepSleep Mode. If this restart is desired, it has to be initiated by the user e.g. double key press or software reset via CAN.

Abort setting during "CANopen baudrate setting"

If there is no button pressed within a timeout period of **60s** the configuration mode would be aborted without any changes concerning CAN baudrate setting and without any store into EEPROM.

Battery is in configuration mode: "CANopen baudrate setting"

If the user has started the configuration mode: "CANopen baudrate setting" by pressing the onBoard button, feedback is given that the configuration mode is initiated. The baudrate can be selected by further user key press interaction and the LED shows which kind auf baudrate is actually selected:

- In case: **125 kBd** is selected
LED continuous flashing: 1 x orange - 1 x green - break...



- In case: **250 kBd** is selected
LED continuous flashing: 1 x orange - 2 x green - break ...



- In case: **500 kBd** is selected
LED continuous flashing: 1 x orange - 3 x green - break ...



- In case: **1 MBd** is selected
LED continuous flashing: 1 x orange - 4 x green - break ...

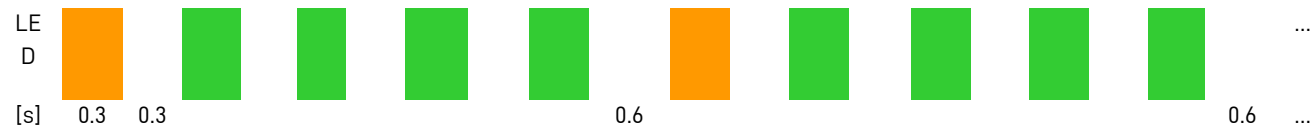

Note: Starting from firmware version V02.09.XX.XX, this option is not supported anymore.

11 Easy Blade - Cooling concept

Please note: This chapter is not applicable for Easy Blade **Baby**.

The Easy Blade has two radial fans to cool the battery in case of increasing temperature. You can see in below spreadsheet the performance of the fans, which depends on the temperature inside the battery. There are different thresholds for charging and discharging.

Discharging:	Charging:	Fan
<30°C	<30°C	off
30°C – 35°C	30°C – 32,5°C	25 %
35°C – 40°C	32.5°C – 35°C	50 %
40°C – 45°C	35°C – 37.5°C	75 %
>45°C	>37.5°C	100 %

Please note for a good circulation, the modules need at least a distance of 5 cm between the battery and the device on both sides (fan side and opposite side). If the batteries are built in into a compartment/enclosure, please ensure fresh air circulation (from outside via slots). The FANs cannot be controlled by the end user via CAN.

Clean Air Flow Cooling:

Appropriate air filtration must be implemented in the final application to prevent contaminants from entering the battery enclosure. Failure to do so may result in product malfunction or failure due to contamination.

12 Charging

Charge algorithm is controlled by the battery itself. Either a VARTA-approved charger can be used or also a customized charger which follows the CANopen standard and the VARTA ASB charger specification, which is available on our homepage for custom developments. Charging will not start without CAN communication.

For the Easy Charger 24 V and 36 V (charger is without any resistor) you need to implement a termination resistor at the charger end. This makes it easier to remove the charger while the bus is still terminated. The

Easy Charger 48 V (ICL1500 58 V) includes already a selectable termination resistor. This could be used when the charger is used as on-board charger and stays connected at the system.

The termination resistor can be implemented e.g. by a Y-cable: 1 plug for the termination resistor and one plug for the charger communication. It is also an option for you to integrate an "easier" way to connect the charger to the battery and to implement the termination resistor in your own adapter.

Charging can be stopped by putting the charger into pre-operational mode. To resume charging, the charger has to be put into operational mode. Please refer to below commands, which are only for our VARTA standard charger like Easy Charger from DeltaQ:

Stop charging: CAN-ID 0x00 Data: 0x80 0x64

Start charging: CAN-ID 0x00 Data: 0x01 0x64

Please note for certain certificates like UL2271 you can only use the chargers, which are listed under chapter 1.4.

12.1 Energy recuperation

Modules accept energy recuperation with below specified limits:

- If current is below 65A for 5s.
- If battery voltage is below:

Products	System voltage [V]
Easy Blade 24 V	29.4
Easy Blade 36 V	42.0
Easy Blade 48 V	58.8
Easy Blade Baby 24 V	29.4

Please note: If the battery exceeds the limits for overvoltage or overcurrent during energy recuperation, the chg FET is opened to protect the battery. If there is still energy recuperation, the voltage on the battery terminals will raise and might damage the HW if the energy is too high. To protect the battery, It is recommended to add bleeding resistors in parallel to the battery which can be switched on in this case. The energy will be dissipated through the bleeding resistors and will not damage the battery.

12.2 Wireless charging

If a wireless charger is used in combination with Easy Blade, below points need to be considered.

The HB Message which is sent from the secondary side of the charger to the battery has to be stopped in following cases to protect the battery from being deeply discharged

- If battery is fully charged
- If primary coil is disconnected from secondary coil (e.g. end application is moving away from charging station)

12.3 Full charge criteria

There are two different types of full charge criteria:

a. Criteria 1

A battery is considered fully charged when its voltage exceeds a specified threshold, and the charging current drops below a predetermined value.

Products	Voltage in CV mode	Current in CV mode
Easy Blade 24 V	> 29.05 V	< 3.2 A
Easy Blade 36 V	> 41.5 V	< 2.24 A
Easy Blade 48 V	> 58.1 V	< 1.6 A
Easy Blade Baby 24 V	> 29.05 V	< 0.96 A

b. Criteria 2

A battery is also considered fully charged when its voltage exceeds a specified threshold for two seconds.

Products	Voltage
Easy Blade 24 V	> 29.4 V
Easy Blade 36 V	> 42 V
Easy Blade 48 V	> 58.8 V
Easy Blade Baby 24 V	> 29.4 V

13 Error

In case of an unexpected behaviour of the battery or if any threshold limit is violated, the battery will store an internal error event. The LED of the battery will be steady red if the operating state does not change. This means that the battery will be operating again, if the cause of the error is not present anymore and the battery is turned off and on again. In case of a non-reversible error, the LED will blink red and the battery cannot be used anymore.

If an error occurs while charging, the charger will be commanded to shut down the charge current and the Charge FET will be opened to prevent any further charging. If an error occurs while discharging, the discharge FET will be opened to prevent any further discharging.

The battery saves the record of every individual error in the internal memory which can be read via CAN from object 0x201A sub 1 to sub 64. The history of the error which occurred can be read from object 0x2018 sub 1 to sub 16 which stores the last 16 events.

Detailed error list can be downloaded on our homepage: www.varta-ag.com/asb

14 The CAN Protocol

Communication between all batteries in the system, the charger and the application (optional), occurs via the standardized CANopen protocol. For more detailed information about CANopen please visit the official website from "CAN in Automation" (CiA) at <https://www.can-cia.org/canopen/>.

At normal operation, all necessary data is transmitted via PDOs in cyclic intervals. If the application needs more information, more data can be accessed via SDO request to the master battery. Please note: Data via SDO shall not be requested during normal operation, only in service cases.

The CAN PDO list can be downloaded on our homepage: www.varta-ag.com/asb

No customized Service software is available. It is recommended the standard CANopen Software for debugging / read-out of CAN Objects, which is CAN Device Explorer from Emotas (<https://www.emotas.de/produkte/canopen-device-explorer>)

CAN EDS file is available on our website to preconfigure the CAN Device Explorer Tool. <https://www.varta-ag.com/de/industrie/service/downloads>

The Node IDs in the system are fixed and not changeable outside the specified range.

14.1 Communication within the battery system

All data required to operate a battery system is transferred via Process Data Objects (PDOs). Each battery transmits data in cyclic intervals with the following definition based on Node ID 1. PDOs sent by other Node IDs increase the CAN-ID, e.g. TPDO_1 sent by Node ID 4 has CAN-ID 0x184.

PDO	CAN-ID	Type	Node-ID	Data		Event
				Battery Voltage	Battery Average Current	
TPDO_1	0x181	PDO	1	uint32 [mV]	int32 [mA]	1s

PDO	CAN-ID	Type	Node-ID	Data				Event
				Max. FET Temp.	Max. Cell Temp.	Charge Voltage Req.	Charge Current Req.	
TPDO_2	0x281	PDO	1	int16 [0.1°C]	int16 [0.1°C]	uint16 [mV]	uint16 [mA]	1s

PDO	CAN-ID	Type	Node-ID	Data				Event
				Battery Cap.	Battery Full Cap.	Battery Rem. Cap.	not used	
TPDO_3	0x381	PDO	1	uint16 [mAh]	uint16 [mAh]	uint16 [mAh]		1s

PDO	CAN-ID	Type	Node-ID	Data				Event
				Information Status	Warning Status	Error Status	Charge Control Status	
TPDO_4	0x481	PDO	1	uint16	uint16	uint16	uint16	100ms

14.2 Communication sent by the battery master (for application)

The battery, which is configured as the master, sends cyclic data of the complete system. Every state of each module is summarized in TPDO_8. In this way only one PDO needs to be checked in case of monitoring the system for faults and errors.

The customer application shall monitor the Master Warning Status Register as well as the Master Error Status Register of the battery (TPDO_8). In case of an active warning, the customer application shall evaluate the warning and shall set counter actions. E.g. If overtemperature warning is set, the customer application shall reduce output power to allow cooling down the battery.

Please note: The customer application shall be setup in a way that the Error thresholds of the battery are not exceeded! In case of an Error, the customer application shall be stopped and the root cause of the failure shall be evaluated. If Bit 6 or Bit 7 or Bit 14 is set, the Battery has a HW damage and shall be removed from the customer application.

PDO	CAN-ID	Type	Node-ID	Data		Event
				Master Voltage (Max. Battery Voltage)	Master Current (sum of all modules)	
TPDO_5	0x19B	PDO	27	uint32 [mV]	int32 [mA]	1s

PDO	CAN-ID	Type	Node-ID	Data			Event
				Max. Battery FET Temperature	Max. Battery Cell Temperature	Master Design Capacity (sum of all modules)	
TPDO_6	0x29B	PDO	27	int16 [0.1°C]	int16 [0.1°C]	uint32 [mAh]	1s

PDO	CAN-ID	Type	Node-ID	Data		Event
				Master Full Charge Capacity (sum of all modules)	Master Remaining Capacity (sum of all modules)	
TPDO_7	0x39B	PDO	27	uint32 [mAh]	uint32 [mAh]	1s

PDO	CAN-ID	Type	Node-ID	Data				Event
				Master Information Status Register	Master Warning Status Register	Master Error Status Register	Master Charge Control Status Register	
TPDO_8	0x49B	PDO	27	uint16	uint16	uint16	uint16	200ms

Battery Information Status Register		
Bit	Description (master / slave)	Detailed Description
15	-	-
14	-	-
13	-	-
12	-	-
11	-	-
10	-	-
9	-	-
8	-	-
7	-	-
6	all modules / this module fully charged	Set if Module is fully charged (100% SoC).
5	-	-
4	bypass FET on	Set if bypass FET is on
3	all modules / this module DSG FET closed	Set if Discharge FET is closed
2	all modules / this module CHG FET closed	Set if Charge FET is closed
1	all modules / this module are almost empty	Set if Module has less than 10% SoC.
0	all modules / this module empty	Set if Module has 0% SoC.

Battery Warning Status Register		
Bit	Description	Detailed Description
15	unknown	Set if other than Bit 0 - 14 warning is set. Please contact Varta in this case.
14	set node ID process enable	During start up of the system the Node IDs are assigned automatically to the individual modules. During this period, the set node ID process enable warning is active.
13	-	-
12	set deactivation enable	If battery is fully charged and the keep power timer has expired or if external ON/OFF switch is pressed, the battery shutdown. The set deactivation enable warning is set prior to this.
11	can network failed	This warning is set if there is a CAN Network failure. E.g. one or more modules cannot communicate on CAN Bus.
10	-	-
9	-	-
8	-	-
7	max charge condition recuperation	Set if battery exceeds overvoltage condition during recuperation.
6	-	-
5	-	-
4	over- or undertemperature charge	Set if temperature exceeds the warning limits during charging
3	over- or undertemperature discharge	Set if temperature exceeds the warning limits during discharging
2	reserve SOC	Set if reserve SoC warning limit is exceeded
1	low SOC	Set if low SoC warning limit is exceeded
0	low voltage	Set if low voltage warning limit is exceeded

Battery Error Status Register		
Bit	Description	Detailed Description
15	unknown	Set if an Error is active which is not covered under B0 - Bit 14.
14	module defect	Set if a HW defect is detected. E.g. short of an internal temperature sensor.
13	over- or undertemperature discharge	Set if the Module exceeds the temperature limits during discharging.
12	over- or undertemperature charge	Set if the Module exceeds the temperature limits during charging.
11	overcharge alarm	Set if Module exceeds the overvoltage limit during charging.
10	undercharge alarm	Set if the Module exceeds undervoltage limit during discharging.
9	max. discharge current alarm	Set if Module exceeds the overcurrent limit during discharging (65A / 3s)
8	max. charge current alarm	Set if Module exceeds the overcurrent limit during charging (65A / 3s)
7	charge FET error	Set if charge FET is damaged.
6	discharge FET error	Set if discharge FET is damaged.
5	max. voltage alarm (pack)	Set if Module exceeds the max allowed voltage of the AFE during charging.
4	shortcircuit discharge alarm	Set if Module exceeds the short circuit limit during discharging (300A / 178µs)
3	shortcircuit charge alarm	Set if Module exceeds the short circuit limit during charging (300A / 178µs)
2	overcharge condition recuperation	Set if Module exceeds overcurrent or overvoltage at charge limits during discharging.
1	error lock flag charge	Set in combination with Bit 12.
0	error lock flag discharge	Set in combination with Bit 13.

Battery Charge Control Status Register		
Bit	Description	Detailed Description
15	Charger supply conditions ready	Set if HB is present AND Master_charger_control_charging_ready (Bit14) is set AND Bit12 Bit13 both Bits are set in RPDO1 (COB-ID 0x1e4)
14	Master charger control charging ready	Set if HB is present AND SDO Initialization sequence has finished
13	Charge FET disable temp range cells	Set if battery temperature exceeds the maximum allowed charging temperature
12	Charge Master set charger output off	Set if battery is fully charged and keep power timer has expired
11	charge max charge cell voltage request	Set if requested charge voltage is at maximum
10	charge max charge current request	Set if requested charge current is at maximum
9	-	
8	charge current high temp range	Set if battery temperature is within high temp range
7	charge current normal temp range	Set if battery temperature is within normal temp range
6	charge current low temp range	Set if battery temperature is within low temp range
5	charge current keep power	Condition1: Set if HB is present and Bit12 or Bit13 or both Bits are not yet set Condition2: Set if HB is present and battery has reached fully charged state
4	charge current enable	Set if HB is present AND SDO Initialization sequence has finished
3	-	
2	-	
1	charge voltage keep power	Condition1: Set if HB is present and Bit12 or Bit13 or both Bits are not yet set Condition2: Set if HB is present and battery has reached fully charged state
0	charge voltage enable	Set if HB is present AND SDO Initialization sequence has finished

Register description in TPDO_8 is similar to TPDO_4 with following interpretation

Information Register: every state of each module is "anded" in this PDO and shows the summary of the system

Warning Register: bit 15..3 of every module is "ored"; bit 2..0 is calculated by master

Error Register: every state of each module is "ored" in this PDO and shows the summary of the system

Charge Control Register: every state of each module is "ored" in this PDO and shows the summary of the system

Error Codes are transmitted in TPDO4 (0x481) and TPDO8 (0x49b). Only 15 Error and 15 Warning Flags can be transmitted via PDO. In some cases, multiple Errors are mapped into the same PDO Error Flag. A more detailed list of Errors can be accessed via SDO (Object 0x201a). Please refer to chapter 0.

14.3 Communication sent by the battery master (for charger)

The master also sends the system requirements for charging to the charging device

PDO	CAN-ID	Type	Node-ID	Data							Event
				Charge Control	SoC		Charge Voltage Req.	Charge Current Req.	Battery Status		
TPDO_9	0x264	PDO	100	uint8	uint8	uint8	uint16 [1/256 V]	uint16 [1/16 A]	uint8	100ms	
Example				0x01	0x64	0x00	0x19	0x1E	0x40	0x02	0x01
					100%		30.097 V		36 A		

The battery master will initialize the charger to the appropriate voltage and current needed to charge the battery system. The voltage and current values requested from the charger will be sent every 100ms. In case of a fully charged battery, the battery will set its "fully charged" flag in the battery information status register (bit 6) and opens its charge FET. When all batteries of the system are fully charged, the master sets its "fully charged" flag and sets the charger to a standby value for the time, which is defined in the object 0x3F00.9 (keep power timer). After this delay, the battery system will shut down. Please see spreadsheet below for the batteries with fixed value in the keep power timer, which cannot be changed. For batteries, which are not fixed the value can be changed see chapter 7.2.

Products	Order number (VKB)	Keep power timer is fixed
Easy Blade 24 V	56654 799 096	No
Easy Blade 36 V	56654 799 089	No
Easy Blade 48 V	56654 799 092	No
Easy Blade Baby 24 V	56672 742 098	No

14.4 Reserved CAN IDs

Following CAN-IDs are reserved by the battery and shall not be blocked from the customer application:

0x601	0x181	0x281	0x381	0x481	0x632
0x602	0x182	0x282	0x382	0x482	0x633
0x603	0x183	0x283	0x383	0x483	0x634
0x604	0x184	0x284	0x384	0x484	0x635
0x605	0x185	0x285	0x385	0x485	0x636
0x606	0x186	0x286	0x386	0x486	0x637
0x607	0x187	0x287	0x387	0x487	0x664
0x608	0x188	0x288	0x388	0x488	0x1e4
0x609	0x189	0x289	0x389	0x489	0x3e4
0x60a	0x18a	0x28a	0x38a	0x48a	0x264
0x60b	0x18b	0x28b	0x38b	0x48b	
0x60c	0x18c	0x28c	0x38c	0x48c	
0x60d	0x18d	0x28d	0x38d	0x48d	
0x60e	0x18e	0x28e	0x38e	0x48e	
0x60f	0x18f	0x28f	0x38f	0x48f	
0x610	0x190	0x290	0x390	0x490	
0x611	0x191	0x291	0x391	0x491	
0x612	0x192	0x292	0x392	0x492	
0x613	0x193	0x293	0x393	0x493	
0x614	0x194	0x294	0x394	0x494	
0x615	0x195	0x295	0x395	0x495	
0x616	0x196	0x296	0x396	0x496	
0x617	0x197	0x297	0x397	0x497	
0x618	0x198	0x298	0x398	0x498	
0x619	0x199	0x299	0x399	0x499	
0x61a	0x19a	0x29a	0x39a	0x48a	
0x61b	0x19b	0x29b	0x39b	0x48b	

15 Life Time / Safety

15.1 Lifetime

The total lifetime of lithium-ion batteries in terms of both calendar life (age) and cycle life (number of full charge/discharge events) is affected by many factors. In general, the more "gently" a battery is treated, the longer it will last and the better the lifetime will be (to a certain limit). The main factors which can negatively impact this would be extremes of temperature, sustained higher or lower temperatures and higher charge or discharge rates (especially if sustained or continuous).

For Easy Blade: Charging current 1C is allowed but 0.5C is recommended for cycle life of 1200 cycles. 1C charging every time will reduce cycle life significantly for the NMC chemistry to around ~300 cycles. The temperature variation is approximately 70% capacity available at -10°C, 85% at 0°C and 100% at 25°C. Colder temperature will increase total charge time. Partial recharges are not a problem, the total number of partial recharges where, for example max charge voltage is never reached or minimum charge voltage is never

reached will extend the total number beyond 1200 cycles. Shelf life: 24 months when shipped from VARTA, conservative estimate.

15.2 Safety & Operation Limits

General for Easy Blade:

Fuse: Siba 5005038.100 (one shot – 100A)

Short circuit protection: 300A / 0.3 ms (reacts faster than the fuse)

Discharge over-current protection 1: 65A / 5s

Discharge over-current protection 2: 85A / 50ms

Charge over-current protection 1: 65A / 5s

Charge over-current protection 2: 85A / 50ms

General for Easy Blade Baby:

Fuse: Siba 5005038.100 (one shot – 100A)

Short circuit protection: 300A / 0.3 ms (reacts faster than the fuse)

Discharge over-current protection 1: 49.5 A / 5s

Discharge over-current protection 2: 57 A / 50ms

Charge over-current protection 1: 18 A / 5s

Charge over-current protection 2: 24 A / 50ms

Individual:

Products	Over - voltage protection	Under-voltage protection	Device Discharge Stop Voltage	Max. Charge Voltage
Easy Blade 24 V	29.75 V / 4s	19.6 V / 2s	21 V	29.05 V
Easy Blade 36 V	42.5 V / 4s	28 V / 2s	30 V	41.5 V
Easy Blade 48 V	59.5 V / 4s	39.2 V / 2s	42 V	58.1 V
Easy Blade Baby 24 V	29.75 V / 4s	19.6 V / 2s	21 V	29.05 V

Following parts can be added across the battery terminals in addition to the built-in protection to protect the battery against overvoltage:

Products	Battery terminals
Easy Blade 24 V	Bourns 15KPA033C
Easy Blade 36 V	Bourns 15KPA043C
Easy Blade 48 V	Bourns 15KPA066C
Easy Blade Baby 24 V	Bourns 15KPA033C

15.3 Storage

In general, storage around room temperature / lower temperatures will be better for long-term battery life (this is applicable to all lithium batteries). Do not store the battery in empty condition to avoid deep discharge.

At the shipping condition of ~25% state of charge level, we estimate 24 months storage conservatively but for such long-term storage we would always recommend a basic voltage check once per year.

16 Calculation: Full charge capacity

The Full Charge Capacity (FCC) of the battery reduces over its lifetime. To account for that fact, the algorithm has a mechanism to learn a new FCC value under the right conditions. **If a battery is discharged from 100 % SOC to 6 %, which equals to EDV1 (0x2804 Sub 2) threshold (3.3V per single cell) without significant recharge (<10 %),** the algorithm will be able to learn a new value for FCC from the counted capacity between these two points.

Please note: It is recommended a re-calibration cycle every 50 cycles. If no re-calibration is performed, the FCC will never change which means the SoH stays at 100%.

You can calculate the SOC:

Formula: $RC / FCC = SOC$

RC= remaining capacity

FCC = Full charge capacity

SOC = State of charge

17 Balancing

17.1 Module level

Balancing is active only during the charging process (constant current and constant voltage phases). It starts when the voltage difference between cells exceeds a defined threshold and stops when it falls below this threshold. The average balancing current is 140 mA. Passive balancing in a battery module involves equalizing the charge levels of individual cells by dissipating energy from higher-charged cells as heat through resistors.

17.2 System level

c. Balancing during charge mode

The balancing process at the system level equalizes the modules step by step. First, the voltage of the less charged modules is aligned. Then, all modules are brought to the same voltage level as the most charged module.

d. Balancing during discharge mode

During the discharge process at the system level, balancing ensures that modules are discharged step by step. The module with the highest voltage is discharged first to match the level of the second most charged module. This process continues until all modules are at the same voltage level.

Recommendation for replacement: If the batteries are replaced, the system voltage should be higher than the voltage of the replacement battery. The opposite could result in current being drawn from only one module, which may reduce overall system performance.

18 Appendix

18.2 Charging cable

Charging cable for charger with firmware A38A & 2270

